

# Kenyon Marine

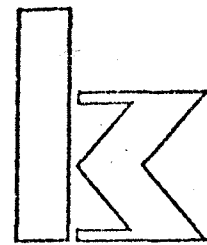

## HOMESTRAND ALCOHOL STOVE, MODEL 500 505

### Instructions and Parts List

The Kenyon Homestrand Model 500 Series stoves are compact gimbal mounted alcohol fueled stoves with integral oven, using the famous Homestrand alcohol burner throughout. The Model 500 stove has two top burners, while the Model 505 has three. The stoves are designed to operate from an external source of alcohol fuel such as the Model H-1000 fuel tank. Standard equipment includes all mounting hardware, flexible fuel connecting hose, two utensil grips, and oven thermometer. The cook top is entirely surrounded by a strong sea rail to help keep cooking utensils secure. The oven door includes a small window with guard.

#### SPECIFICATIONS

FUEL: Denatured 95% ethyl alcohol stove fuel or 91% iso-propyl alcohol stove fuel containing less than 0.003% by weight non-volatile matter.

FUEL SUPPLY PRESSURE: 10 psig nominal, 35 psig maximum.

BURNER OUTPUT: 2800 BTU/hr. (Ethyl Alcohol)  
3000 BTU/hr. (Iso-propyl Alcohol)

	<u>H500</u>	<u>H505</u>	
TOP AREA:	12 1/4	15 1/2	Deep
	20 1/2	20 1/2	Wide
OVEN CAPACITY:	11 1/4	14 3/4	Deep
	15	15	Wide
	9 1/2	9 1/2	High
RANGE OUTLINE:	16 1/2	19 1/2	Deep
	21 1/2	21 1/2	Wide
	21 1/2	21 1/2	High
SHIPPING WEIGHT:	60	65	lb.
	7.5	7.5	cu. ft.

## INSTALLATION

Select a location for your Model 500 stove which permits adequate ventilation and yet which is sheltered from excessive exposure to wind or rough handling. The ranges are normally mounted facing athwartships in a counter recess. Installation should be in accordance with applicable sections of NFPA Code, No. 302 which are reproduced elsewhere. Copies of the code may be obtained from - National Fire Protection Association, 470 Atlantic Avenue, Boston, Massachusetts, 02210 at \$2.00 each. The stove must be permanently and securely fastened, and surrounding materials must be protected from fire.

**CUTOUT** Prepare the counter as shown in the Figure. The dimensions shown in the accompanying table are determined from the dimensions of the range with an allowance for a 45° swing either side of vertical. Note that at 45°, the rear edge of the stove extends back 12 inches from the vertical position and the forward edge extends 13 inches forward of the vertical position. The cutout must be sheathed with fireproof material for safety, ease of cleaning, and to prevent pressure differentials from communicating through cabinetry into the stove.

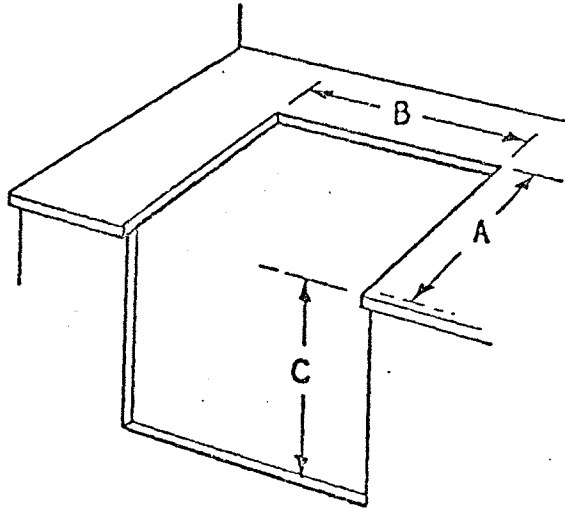

	A	B	C
H500	20"	22"	22"
H505	24"	22"	23"

MODEL 500

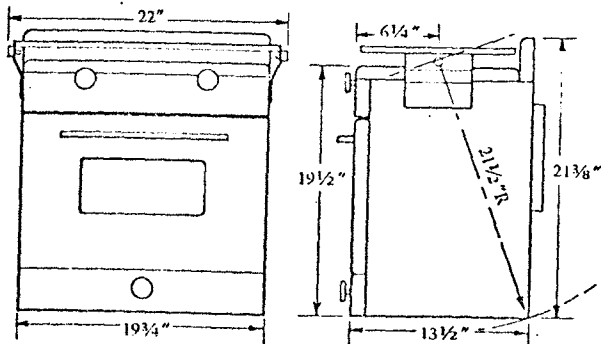

MODEL 505

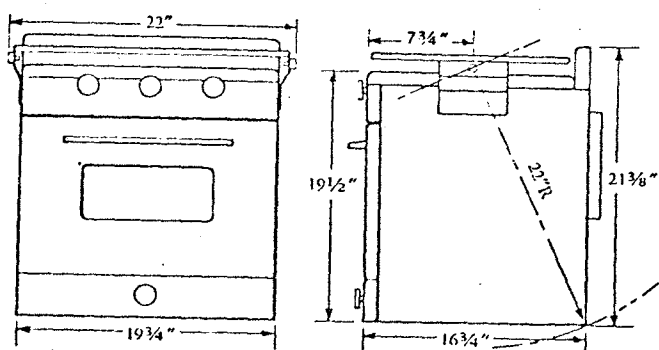

**MOUNTING** Determine the location of the gimbal pins and mount them on either side of the cutout with the screws in a horizontal plane. Dismount one pin and temporarily tape it to the gimbal bracket with the pin through the center hole. Before mounting the stove it is usually easier to attach the flexible hose as described below. Position the stove on the mounted gimbal pin and remount the other pin through the 2 access holes provided in the gimbal bracket.

**FUELING** Connect one end of the flexible fuel hose to the distribution block at the rear left top corner of the stove. Experimentally determine the mounting position for the other end which allows free swing of the stove without binding or abrasion. Connection to the remote alcohol supply may be direct, or through 1/4" OD tube using 45° SAE flare fittings. Secure the flexible hose with a suitable clamp to prevent fatigue damage to the copper tubing if used.

**CHAPTER 4. COOKING, HEATING AND  
AUXILIARY APPLIANCES**

40. Open flame devices are more liable to promiscuous, unskilled or ignorant operation than any other boat equipment involving fire risk. It is therefore imperative that such items be selected and installed with the aim of minimizing personal and physical hazards.

**41. Cooking Equipment.**

411. Galley stoves shall be manufactured, approved and labeled for marine use. Printed instructions for proper installation, operation and maintenance shall be furnished by the manufacturer. A durable and permanently legible instruction sign covering safe operation and maintenance shall be provided by the manufacturer and installed on or adjacent to the consuming appliance, where it may be readily read.

(a) Stoves shall be installed in adequately ventilated areas to comply with Paragraph 113.

(b) Stoves shall be securely fastened when in use and when stored.

(c) Any burner system that may affect safety by reason of motion of the boat shall not be used.

(d) All woodwork or other combustible materials above stove tops and all woodwork or combustibles immediately surrounding stoves shall be effectively insulated with noncombustible materials or sheathing.

**413. Alcohol, Fuel Oil and Kerosene Stoves.**

(a) Either pressure or gravity fed burners are permissible.

(b) Fuel supply tanks shall be constructed of corrosion resistant metal with welded or brazed joints and fittings.

(1) Pressure tanks integrally installed with stoves shall withstand a test pressure of at least 200 pounds per square inch gage.

(2) Pressure tanks integrally installed with stoves shall be effectively protected from the heat of the burners.

(3) Pressure tanks for remote installation shall be approved and be able to withstand a test pressure of at least 100 pounds per square inch gage.

(4) Pressure tanks remotely installed shall be rigidly secured in an accessible location permitting convenient filling and pump operation.

(5) Gravity tanks shall be substantially secured and should be remote from stoves. In any event, they shall be so located or shielded that under continuous operation at maximum output, the temperature of contained fuel will not be substantially raised by heat from burners.

(6) No gravity tank shall have a capacity exceeding 2 gallons. Tanks of larger capacity shall be in accordance with Section 31.

(7) Gravity tanks should have provision for filling and venting outside galley space.

(c) When fuel tanks are remotely located, as is preferred for gravity feed systems, approved stop valves shall be installed close to tanks and fuel lines shall be installed with as few fittings as practicable between valves and stove connections.

(d) If solidified fuel is used, the containers shall be properly secured on a fixed base to prevent sliding or overturning in a sudden roll of the vessel.

## OPERATION

### PREPARATION

Alcohol for the Model 500 Series stoves is supplied from a remote pressurized tank. Before operating the stove, check that all top burners and oven burner are closed (fully clockwise). Close the alcohol vent cap and pressurize the tank to approximately 10 pounds.

### TO LIGHT A BURNER

The burner must be primed (heated) to operating temperature before use. After hot it operates like a regular gas burner. If allowed to cool, the burner must be re-primed.

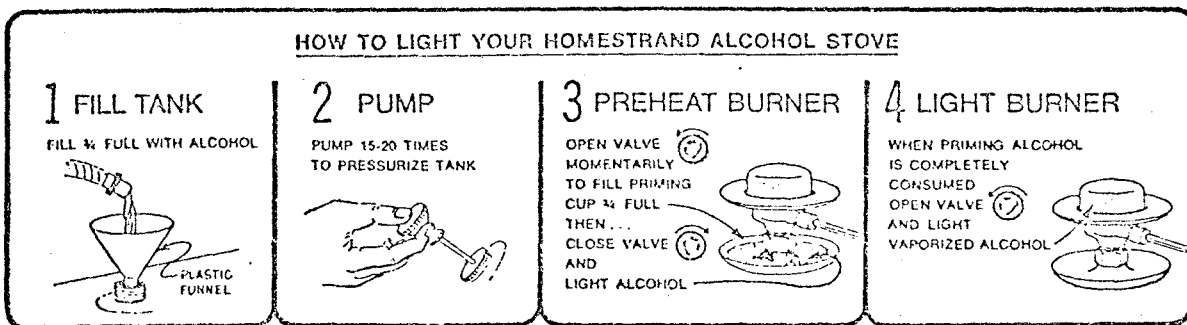

### CAUTIONS

1. Do not put utensils over the burner until it is operating.
2. Do not try to fill the burner flange. The priming cup is located at the bottom of the burner.
3. If too much priming alcohol is used, the flame will flare up. If too little is used, the burner will not get hot enough.

### TO SHUT OFF A BURNER

Turn control wheel all the way to the clockwise position. The burner may be used again without priming if hot enough. Otherwise it will have to be primed.

### TO CLEAN A BURNER

The burner orifice may be cleaned by rotating the burner control to the extreme counter-clockwise position, and then returning to the clockwise position.

## OVEN OPERATION

The oven heat is generated by an alcohol burner located under the baffle plates at the bottom of the oven. Operation of this burner is the same as described above, except that the baffles must be raised to prime the burner. Temperature control is by manual adjustment of the burner flame with the control under the oven door.

### CAUTION

Care should be taken not to let the burner go out while adjusting because of the difficulty of relighting it.

### IN CASE OF FIRE

USE WATER TO PUT OUT ALCOHOL FIRES.

SMOTHER GREASE FIRES OR USE BAKING SODA  
OR A CLASS B FIRE EXTINGUISHER.

## THEORY OF OPERATION

Model 500 burners use alcohol vapor for fuel. This gaseous fuel is produced by boiling liquid alcohol in the base of the burner by diverting some of the heat from the flame through the burner body.

In order to start a cold burner, it must first be heated above 180°F in order to produce the required vapor. This is usually done by burning a small amount (about 1/4 oz.) of liquid alcohol in a special priming cup under the base of the burner. As the burner heats up, the liquid alcohol trapped in the burner boils, causing a flame to appear at the burner cap. If the priming cup is too full, the rising temperature also causes the priming alcohol to boil which produces a relatively high flame around the burner before it boils away. These conditions, usually termed "flare-up" are a natural consequence of the priming process and are usually not serious. A little practice will show the correct amount of alcohol necessary to produce the required temperature. Too much alcohol will produce "flare-up" and too little will not bring the burner to a high enough temperature. A hot burner will produce a hissing sound when turned on. A cold burner will be silent or produce a squirting sound, and liquid alcohol will flow down into the priming cup. After priming, the burner must be lit before it cools off, or re-priming will be necessary.

When operating, liquid alcohol is delivered under pressure from the supply tank to the burner base. The liquid makes contact with the hot strainer (7), and boils, producing alcohol vapor, which travels through the body (1), through the metering valve (2), and through the orifice (4). Air is drawn up through the air holes in the flange, mixes with the vapor and passes through the outer cap (6), where it burns. As the metering valve opens, a cleaning rack (3) moves up toward the orifice (4). The arrangement is such that about 1/2 turn after opening, the clearing needle passes through the orifice, clearing out the hole.

STOVE PARTS LIST

ITEM	DESCRIPTION	MODEL 500		MODEL 505	
		Qty	Part #	Qty	Part #
1	Left Side Panel	1	H2312-1	1	H2313-1
	Right " "	1	H2312-2	1	H2313-2
2	Top	1	H2314	1	H2315
	Backsplash Panel	1	H2316	1	H2316
3	Grate	2	H2162	3	H2162
4	Grate Clip	6	H1018-4	9	H1018-4
5	Drip Pan	1	H2011	1	H2005
6	Knob, Front Burner	2	H2020	2	H2020
7	Knob, Rear Burner	-	-	1	H2021
8	Knob, Oven	1	H2022	1	H2023
9	Spring	3	H2017	4	H2017
10	Retainer	3	H2016	4	H2016
11	Liner	2	H1699	3	H1699
12	Washer	1	H2049	1	H2049
13	Oven Shelf	1	H2118	1	H2120
14	Oven Burner Cover	1	H2119	1	H2121
15	Oven Air Baffle	1	H2097	1	H2098
16	Oven Window	1	H2160	1	H2160
	Oven Window Guard	1	H2052	1	H2052
17	Gimbal Pin	2	H1994	2	H1994
18	Sea Rail	1	H2007	1	H1987
19	Left Utensil Holder	1	H2009	1	H2009
	Right " "	1	H2026	1	H2026
20	Burner	3	H2000	4	H2000
21	Hose	1	H2047-1	1	H2047-1

BURNER PARTS LIST

H2000 BURNER

ITEM	DESCRIPTION	QUANTITY	PART #
1	Burner Body	1	H2052
2	Control Assembly	1	H1123
3	Cleaning Rack	1	H1323
4	Nozzle	1	H1117
5	Inner Cap	1	H1128
6	Outer Cap	1	H1127
7	Filter Screen	1	H1469 H2068
8	Packing Priming Cup	1	H2307 H1673
	Renewal Kit	0	H2300
	Consists of Items 2 thru 7		

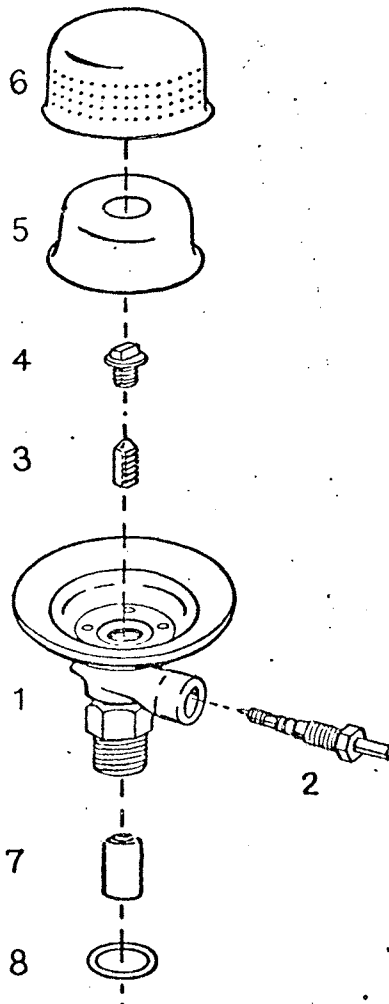

HOMESTRAND MODEL 505

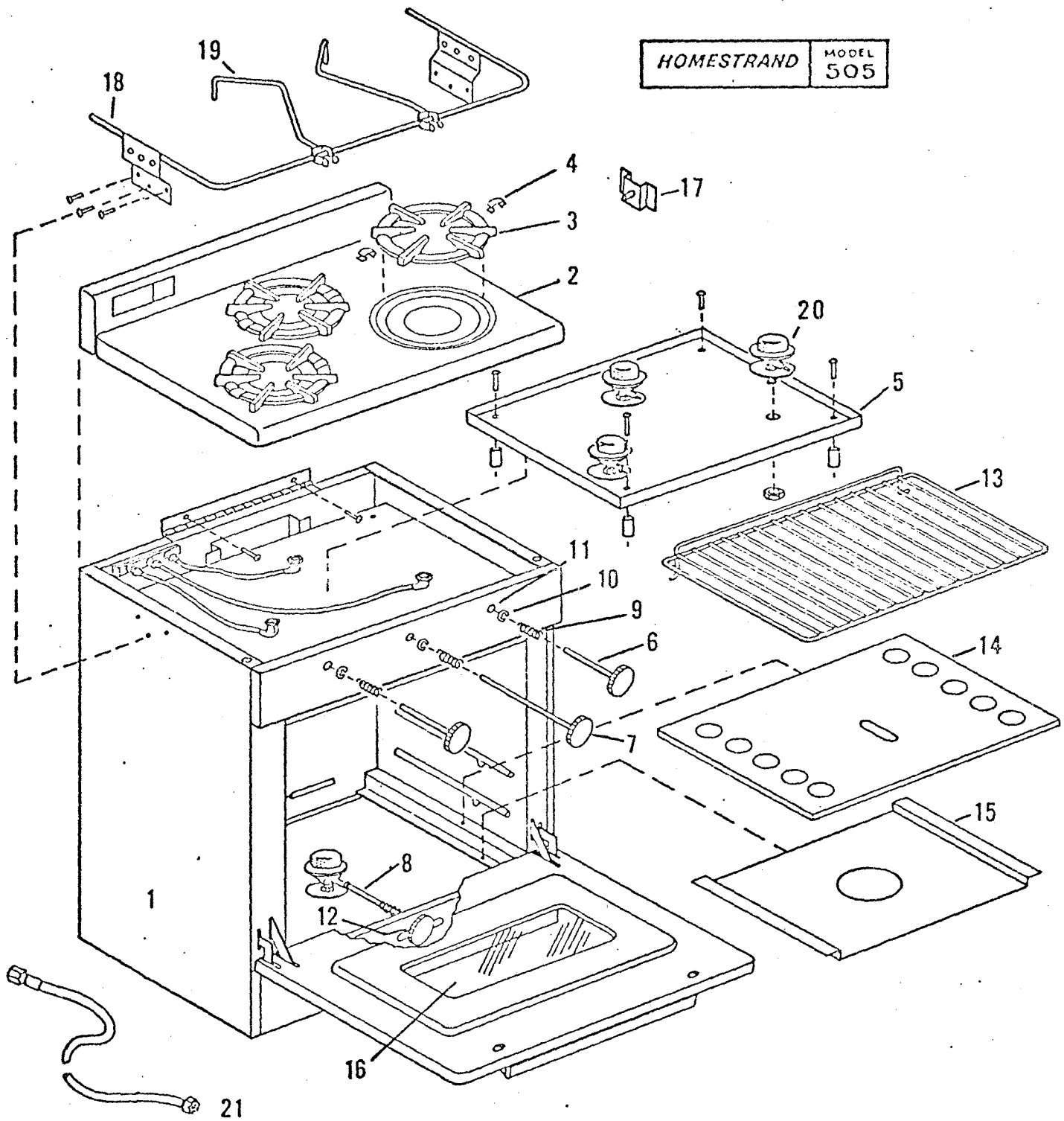

HOMESTRAND MODEL 500

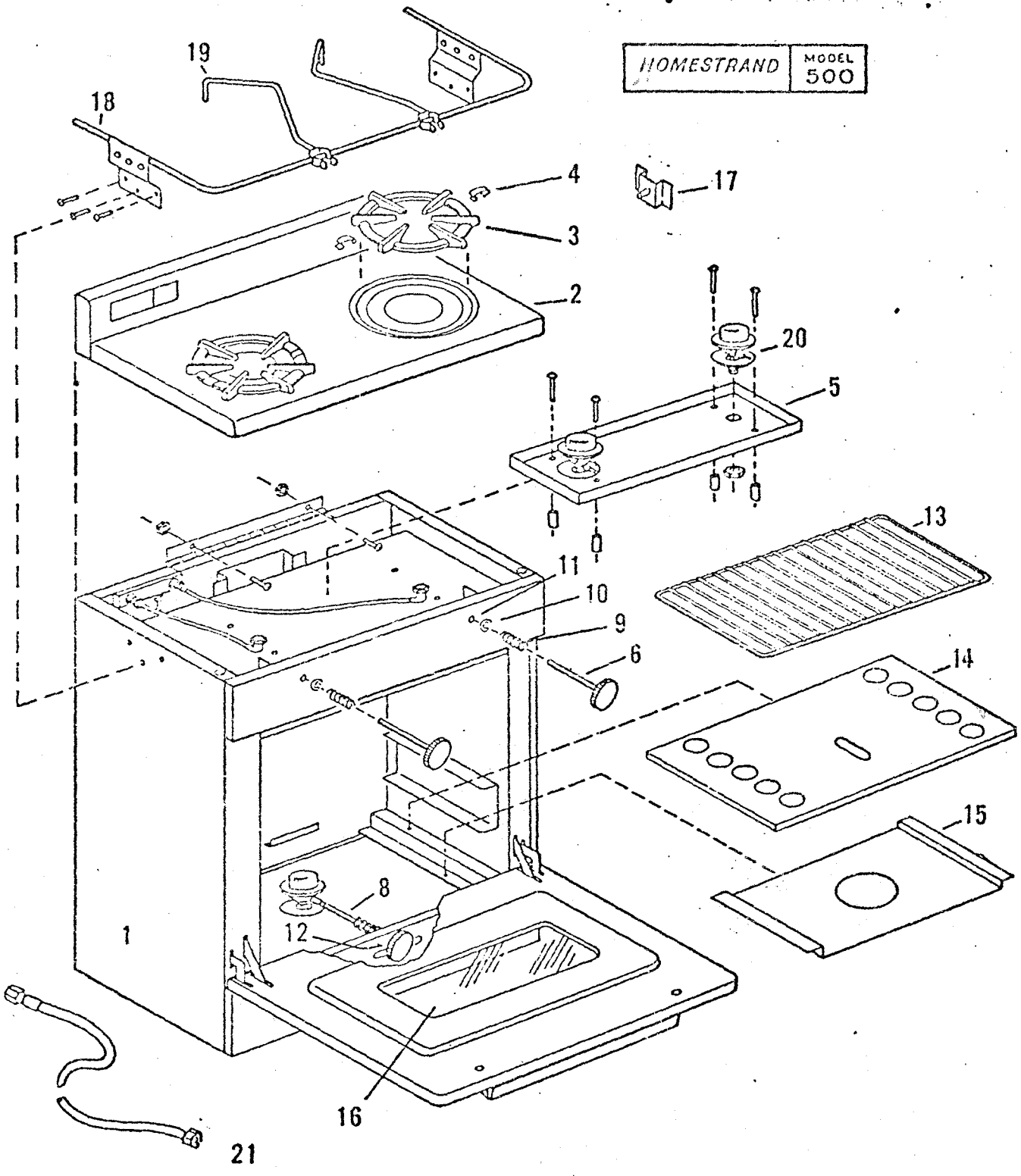

ESS-KAY YARDS, INC.  
PO BOX 68  
BREWERTON, NY 13029  
315-676-2711phone/676-7064fax

---

# INSTRUCTION MANUAL

Alcohol Burner Renewal Kit B93029

FOR

Models 500, 505, 550, 555

---

PLEASE KEEP THIS MANUAL ABOARD YOUR BOAT

## **REBUILDING ALCOHOL BURNERS IN KENYON HOMESTRAND STOVES WITH OVENS.**

Stoves may be either two or three burner. You may encounter two types of alcohol burner assemblies – the H-2000 and the B70040. You should be able to identify the various model stoves and burners by reviewing the illustrations in this manual.

Before starting to disassemble the stove, depressurize tank and shut off the remote tank supply line.

In the following sections, please refer to the corresponding parts list for item numbers shown in parenthesis.

### **REMOVAL OF TOP BURNERS**

Instructions 1-4 below apply to all models. (500, 505, 550, and 555)

1. Lift stove top (2) up and back – top is hinged.
2. Pull the pin which locks the control stem to the burner valve spindle (550/555 only)
3. Remove horseshoe clip (10) on each control stem by grasping with pliers and pulling out.
4. Slide control knob and stem (6) out – sliding off spring (9) and washer on each one.

Instructions 5-11 below apply only to Models 500 and 505. (It is not necessary to remove the B70040 alcohol burners from the 550 or 555 stove in order to rebuild them.)

5. Remove the top burner feed line(s) from the manifold at the back of the stove using a 7/16" wrench.
6. Remove 4 phillips head screws holding burner tray (5) in place.
7. Remove tray and burners from stove.
8. Remove feed lines from elbow on each burner using 7/16" wrench.
9. Remove elbow using 7/16" wrench.
10. Remove 3/4" nut holding burner to tray
11. Remove burner

### **REMOVAL OF OVEN BURNER**

Instructions 1-4 below apply to all models.

1. Remove grate (13), heat deflector (14) and splash tray (15) from oven.
2. Pull the pin which locks the control stem to the burner valve spindle (550/555 only)
3. Remove horseshoe clip from oven control stem by grasping with pliers and pulling off.
4. Slide control knob and stem out – sliding off spring and washer.

Instructions 5-8 below apply only to Models 500 or 505. (It is not necessary to remove the B70040 alcohol burners from the 550 or 555 stove in order to rebuild them.) The B93069 kit contains screen filters which are discarded for these applications.

5. Unscrew 7/16" nut on feed line.
6. Remove elbow with 7/16" wrench.
7. Remove 3/4" nut on burners
8. Remove burner.

### **REMOVAL OF FILTER IN ELBOW**

Models 500 and 505 only

1. Hold the elbow and fitting in a vise.
2. Obtain a No. 16, No. 17 or 11/64" diam. drill.
3. Mark the length of the elbow filter (5/8") on the drill by wrapping with masking tape.
4. Drill the exact center of the sintered bronze filter element, drilling only to the filter depth as marked on the drill.
5. Remove the filter from the elbow with needle nose pliers.
6. Carefully clean all foreign particles out of elbow fitting.

### **INSTALLING NEW FILTER IN ELBOW**

Models 500 and 505 only

1. Wrap elbow filter screen (10) around pre-rolled filter (9) until a tight fit into elbow is obtained.
2. Insert filter into elbow fittings.

### **REMOVING THE FILTER IN BURNER**

Models 500 and 505 only

1. Hold burner upside down in vise.
2. Grasp filter with needle nose pliers and pull out both filter screen and sintered bronze filter. In some cases, the filter may be too tight to remove in this manner. If so, proceed with the following steps:
3. Obtain a No. 16, No. 17 or an 11/64" diameter drill.
4. Mark the length of the filter (7) 1/2" on the drill by wrapping with masking tape.
5. Drill into the exact center of the sintered bronze filter element. Drill to only 1/2 of the depth of the filter element (approximately 1/4"). Drill carefully, as the filter element itself will drill easily with a sharp drill. Do not drill off center or threads inside burner may be damaged.
6. Remove the burner from the vise and attempt to tap the filter element out of the burner base.
7. If the filter element cannot be removed, clamp the burner in the vise and drill to the full filter depth (1/2" as previously marked on the drill). DO NOT GO DEEPER, AS THE BURNER WILL BE DAMAGED.
8. Carefully clean all foreign particles out of the burner base. A blast of compressed air is recommended.

### REMOVING THE FILTER IN B70040 BURNER

Models 550 and 555 only

1. Hold burner base with 3/4" wrench and grasp burner body just under the flange with vise grips. Unscrew the top, being sure to hold the base fixed so the feedpipe will not be twisted.
2. The fiberglass filter will be visible in the base of the burner. Grip the the filter with tweezers and pull it out of the burner base.

### DISASSEMBLING THE BURNER

1. Remove the outer burner cap (6) by prying up with the corner of a screwdriver.
2. Lift off the inner burner cap (5)
3. Unscrew the burner nozzle (4). A special wrench, H525, is recommended.
4. Remove the cleaning needle (3) by turning the burner valve spindle (2) counterclockwise. This will disengage the cleaning needle gears from the valve spindle and the cleaning needle will drop out when the burner is turned upside down. (May be lifted out with tweezers or by pushing a pencil eraser onto the wire.)
5. Unscrew the gland nut (2) from the burner body using a 3/8" wrench.
6. Turn the burner valve spindle (2) counterclockwise until the threads disengage from the burner body (1) and the spindle can be pulled out. The packing and washers will come out with the valve spindle.

### INSTALLING THE NEW FILTER IN BURNER

Models 500 and 505 only

1. Make sure the burner is free from foreign matter inside. A compressed air blast is recommended.
2. Wrap the burner filter screen (8) tightly around the burner sintered bronze filter (7) and insert both into the burner base.

### INSTALLING THE NEW FILTER IN B70040 BURNER

Models 550 and 555 only

1. Make sure the burner base is clean and free of dirt or debris from the old filter.
2. Fold the filter braid tubing into a "U" shape as shown in the burner drawing.
3. Insert a small wire (like a straightened section of a paper clip) into half the braid and push it into the burner base as far as it will go.
4. Hold the filter in place and remove the wire.
5. Trim the braid filter with scissors so that only about 1/8" extends out of the burner base.
6. Install a new copper washer onto the burner body and screw the burner body into the burner base; hand tightened.
7. Hold the burner base with a 3/4" wrench and tighten the body using locking pliers. Tighten no more than one turn until the valve spindle points straight forward to line up with the control rod.

### INSTALLING THE NEW VALVE SPINDLE

1. Insert the new valve spindle assembly (2) into the burner and screw it in as far as it will go. The gear on the valve spindle should show all the way across one side of the hole in the body when looking down from the top.
2. Push in the washers and packing and install the gland nut
3. Rotate the control stem back and forth and tighten the gland nut until the packing is seated and a slight, but definite resistance can be felt when turning the control stem.

### INSTALLING THE CLEANING NEEDLE

1. Turn the control stem (2) clockwise until the burner is closed and the needle valve is seated.
2. Put the cleaning needle (3) into the burner with the teeth facing the gear of the valve spindle (2). It is convenient to hold the cleaning needle by inserting the wire into the eraser of a pencil.
3. Rotate the control knob counterclockwise slowly while lightly pushing the cleaning needle down into the burner so that the lowest track tooth rests against the teeth of the valve spindle. As each tooth of gear moves by, a "click" can be heard and felt in the cleaning needle. Stop turning the valve spindle after five "clicks."
4. Now, rotate the control stem (2) clockwise slowly so that the cleaning needle and valve spindle teeth engage. As the control stem (2) is rotated further clockwise to the closed position, the cleaning needle (3) will be drawn down into the burner. No increase in resistance should be felt. If the needle jams, remove the needle and try again from Step 1.
5. Note: When the burner valve (2) is fully closed, check that the top tooth of the cleaning needle rack (3) is still above the center of the gear on the valve spindle (2). If the cleaning needle (3) is too deep in the burner, it may bottom out before the needle valve (2) has closed completely. If not sure, repeat the procedure from Step 1, being sure that only five clicks are heard in Step 3.

### INSTALLING NOZZLE AND CAPS

1. Screw the nozzle (4) in place and tighten firmly. The use of wrench H-525 is recommended.
2. Turn the valve spindle (2) to the closed position
3. Turn the valve spindle 92) counterclockwise until it stops. This should be just over 1/2 turn of the valve spindle. If less than 1/2 turn is found from fully closed to "clean" position, the cleaning needle has not been properly installed and that assembly should be performed again. In the "clean" position, completely counterclockwise, the cleaning wire (3) should be seen protruding slightly through the nozzle hole.
4. Place the inner cap (5) in position on the burner
5. Place the outer cap (6) in position and snap it into place. A slight tap with a wood block or screwdriver may be required to seat the cap.

### ASSEMBLING THE BURNER TO TOP TRAY

Model 500 and 505 only

1. Push priming cup onto burner before inserting burner into the hole in the tray.
2. Install new copper washer (8) onto burner base (under tray).
3. Install 3/4" nut and tighten, making sure valve spindle is in line with hole for control stem - repeat for each top burner.
4. Screw elbow into place. Tighten elbow so that it will properly align.
5. Install feed pipes to elbow. Remember, they must match up with manifold block at left rear corner of stove.
6. Reinstall tray with burners to stove.
7. Tighten and install feed line to manifold block at left rear corner of stove.
8. Install control knob and stems - slide stem through hole, then slide on washer and spring. Push control stem onto the burner valve spindle (2).
9. Install horseshoe clip to stem by holding control knob in place, sliding back spring and pushing U clip into indent in stem.

### INSTALLING OVEN BURNER

Model 500 and 505

1. Install priming cup by pushing on burner oven threads.
2. Install burner through hole making sure valve spindle is in proper position to install control wheel and stem.
3. Install packing washer.
4. Install and tighten 3/4" nut.
5. Install elbow and fuel line and tighten.
6. Install control knob and stem per 8 and 9 above.

### INSTALLING CONTROL STEM

Model 550 and 555

1. Slide control stem through hole in front of stove, then slide on spring and stem.
2. Install horseshoe clip to stem by holding control knob in place, sliding back spring and pushing U clip into indent in stem.
3. Turn control knob until the hole in stem lines up with hole in burner valve spindle, then insert pin to lock them together.

# MODEL 505

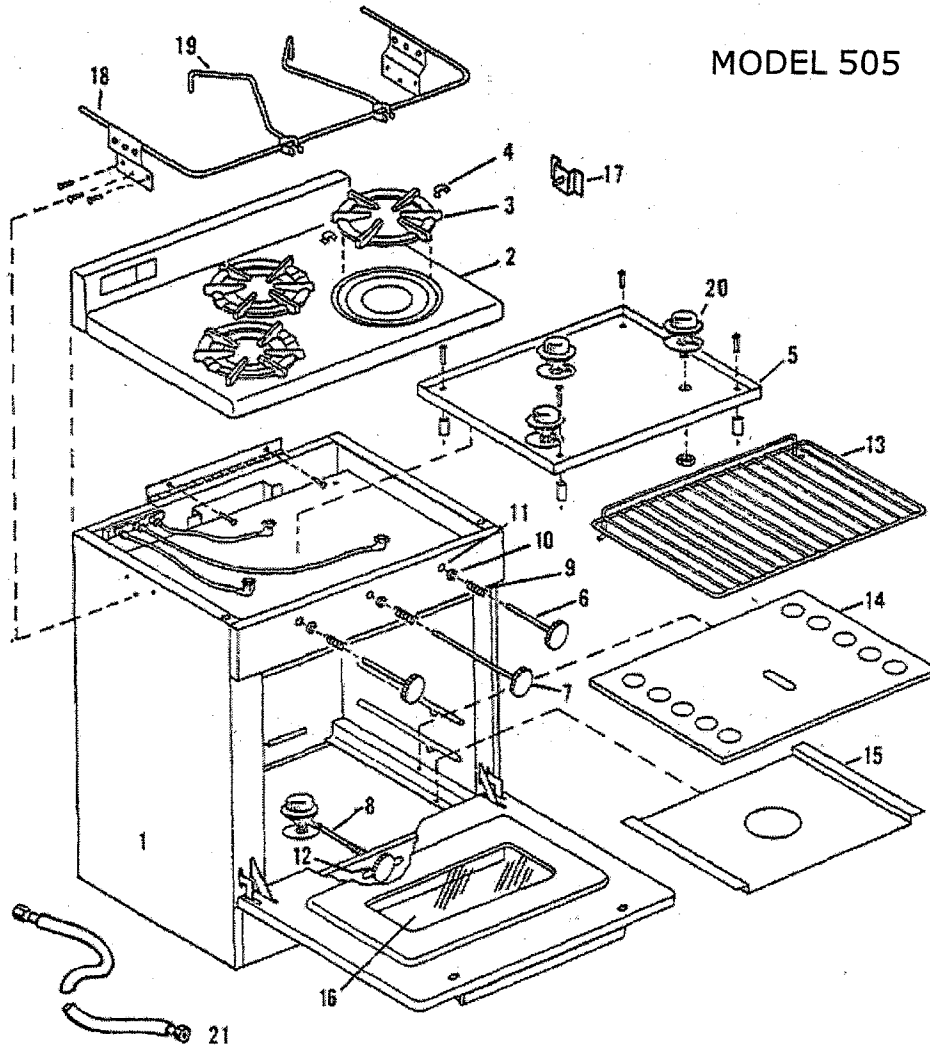

ITEM	DESCRIPTION	QTY.	PART #
1	Left side panel	1	H2313-1
	Right side panel	1	H2313-2
2	Top side panel	1	H2315
	Backsplash panel	1	H2316
3	Grate	3	H2162
4	Grate clip	9	H1018-4
5	Drip pan	1	H2005
6	Knob, front burner	2	H2020
7	Knob, rear burner	1	H2021
8	Knob, oven	1	H2023
9	Spring	4	H2017
10	Retainer	4	H2016
11	Liner	3	H1699
12	Washer	1	H2049
13	Oven shelf	1	H2120
14	Oven burner cover	1	H2121
15	Oven air baffle	1	H2098
16	Oven window	1	H2160
	Oven window guard	1	H2052
17	Gimbal pin	2	H1994
18	Sea rail	1	H1987
19	Left utensil holder	1	H2009
	Right utensil holder	1	H2026
20	Burner	4	H2000
21	Hose	1	H2047-1

MODEL 500

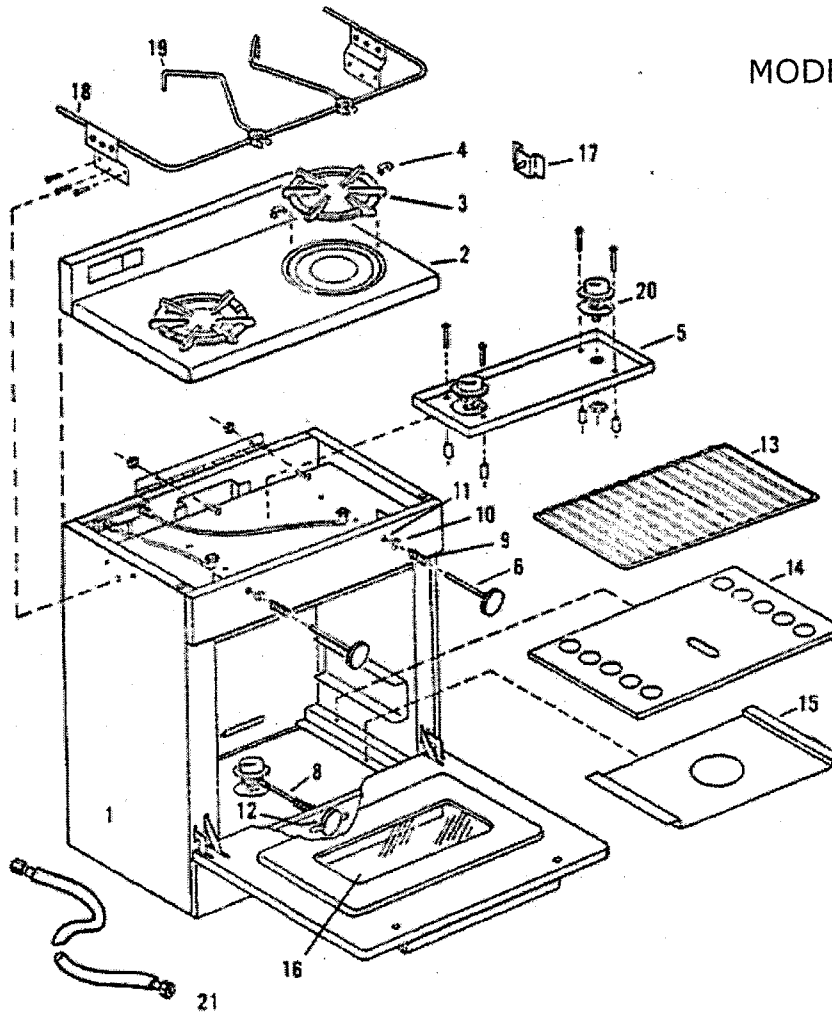

ITEM	DESCRIPTION	QTY.	PART #
1	Left side panel	1	H2312-1
	Right side panel	1	H2312-2
2	Top side panel	1	H2314
	Backsplash panel	1	H2316
3	Grate	2	H2162
4	Grate clip	6	H1018-4
5	Drip pan	1	H2011
6	Knob, front burner	2	H2020
8	Knob, oven	1	H2022
9	Spring	3	H2017
10	Retainer	3	H2016
11	Liner	2	H1699
12	Washer	1	H2049
13	Oven shelf	1	H2118
14	Oven burner cover	1	H2119
15	Oven air baffle	1	H2097
16	Oven window	1	H2160
	Oven window guard	1	H2052
17	Gimbal pin	2	H1994
18	Sea rail	1	H2007
19	Left utensil holder	1	H2009
	Right utensil holder	1	H2026
20	Burner	3	H2000
21	Hose	1	H2047-1

# MODEL 550

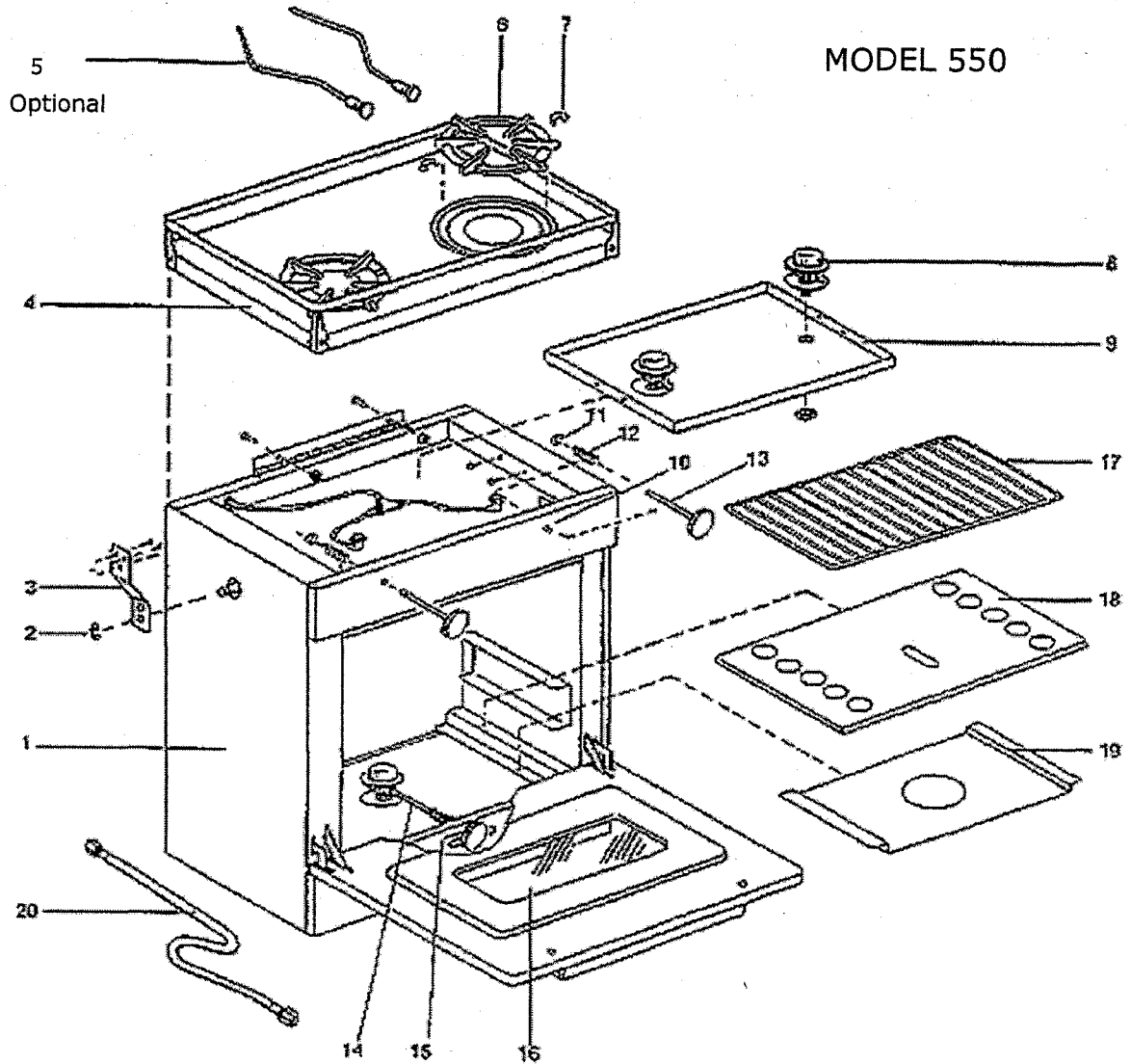

ITEM	DESCRIPTION	QTY.	PART #
1	Left side panel	1	142-140
	Right side panel	1	142-141
	"E" Ring	2	063-009
	Gimbal bracket	2	141-081
	Range top assembly, Coppertone	1	240-146
	Range top assembly, stainless	1	240-202
	Top pan assembly	1	240-146
Optional	Right utensil holder	1	H2378
	Left utensil holder	1	H2377
	Grate	2	H2162
	Grate clip	6	H1018-4
	Burner assembly-alcohol	3	B70040
	Drip pan	1	142-066
	Liner	2	H1699
	Retainer	3	H2016
	Spring	3	H2017
	Knob, front burner	2	240-165
	Knob, oven	1	240-166
	Washer	1	H2049
	Oven window	1	H2160
	Oven shelf	1	H2118
	Oven burner cover	1	H2119
	Oven air baffle	1	H2097
	Hose assembly	1	240-134

# MODEL 555

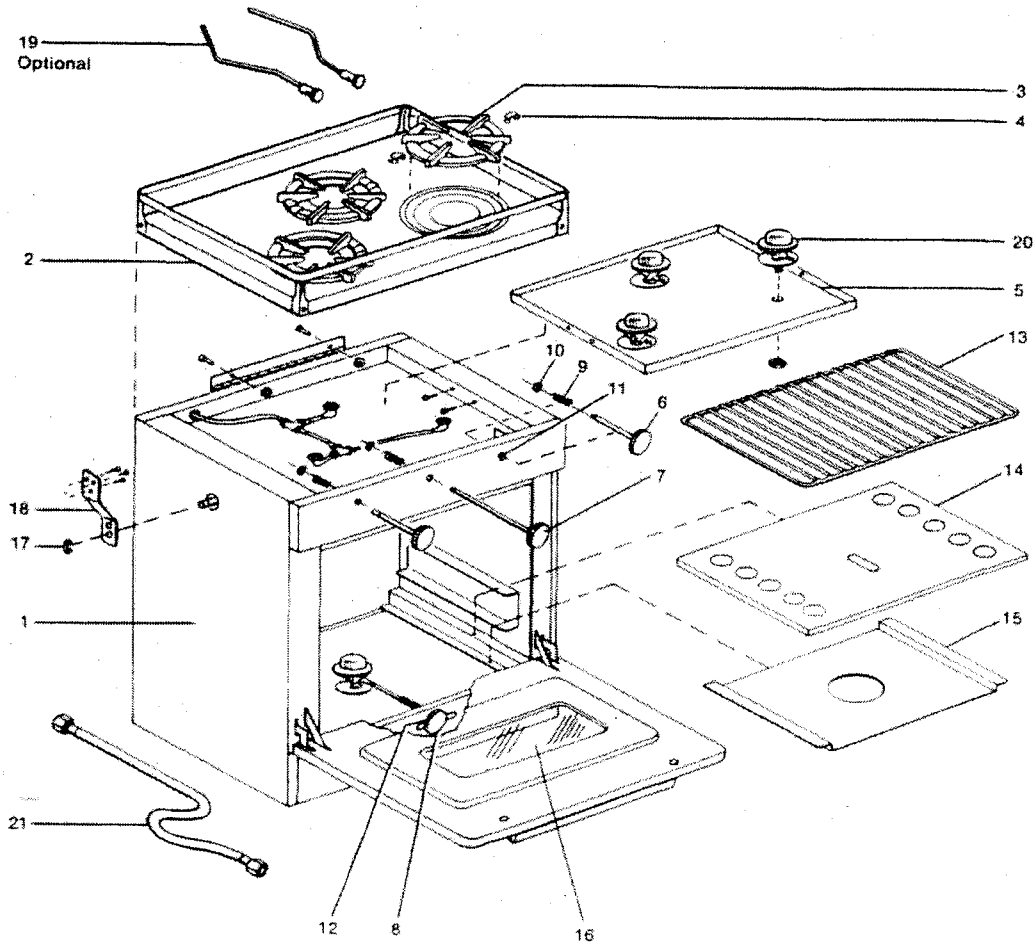

ITEM	DESCRIPTION	QTY.	PART #
1	Left side panel	1	142-108
	Right side panel	1	142-107
2	Range top assembly, coppertone	1	240-152
	Range top assembly, stainless	1	240-203
3	Grate	3	H2162
4	Grate clip	9	H1018-4
5	Drip pan	1	142-106
6	Knob, front burner	2	240-165
7	Knob, rear burner	1	240-171
8	Knob, oven	1	240-172
9	Spring	4	H2017
10	Retainer	4	H2016
11	Liner	3	H1699
12	Washer	1	H2049
13	Oven shelf	1	H2120
14	Oven burner cover	1	H2121
15	Oven air baffle	1	H2098
16	Oven window	1	H2160
17	"E" Ring	2	063-009
18	Gimbal bracket	2	141-081
Optional 19	Left utensil holder	1	H2377
	Right utensil holder	1	H2378
20	Burner-alcohol	4	B70040
21	Hose assembly	1	240-134