

Walter V-Drives

Independent Models

Installation, Operation and Maintenance Manual Models RV-10, RV-20, RV-30, RV-40 & RV-48

- V-Driving is the most advanced method of boat propulsion. America's fastest cruisers are equipped with V-Drives. By placing the engines in the stern more usable space is provided for living quarters on pleasure boats and cargo space on work boats. The engine compartment becomes a very compact unit and can be bulkheaded from the rest of the boat reducing engine noise and increasing safety. It also results in easier installation and greater accessibility of the engines. V-Drives also make it possible to use inboard engines in small cruisers without sacrificing valuable cabin space.

- Only direct drive (1:1 ratio) reverse gears are required. All reduction gearing is incorporated in the V-Drive, eliminating the need for an additional unit on the reverse gear.

- Walter V-Drives are revolutionary. Conventional V-Drives use angle gears and housings to provide the V-angle. Walter V-Drives accomplish this by employing special coupled cardan type constant velocity needle bearing universal joints, fully encased and effectively lubricated by the gear drive lube system. The gears and shafts are parallel and a number of standard gear ratios are available for each size V-Drive.

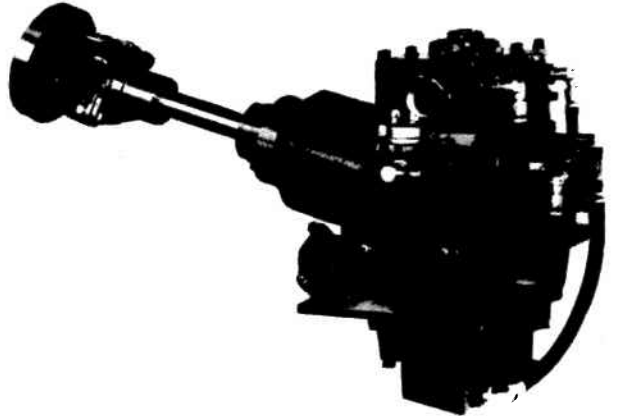

Flange Alignment

- Install the #25 propeller shaft flange on to the propeller shaft and tighten the two clamping bolts on the split hub (none on RV-10). A self-locking set screw is provided for the propeller shaft flange. Spot drill the propeller shaft and securely tighten the set screw.

All V-Drives are supplied with 3-way adjustable mounting brackets (2-way on the RV-10 and RV-20) as standard equipment. The brackets must face downward as shown in the illustration to properly absorb propeller thrust. The mounting plates can be removed and reversed to fit wider engine bed centers. Before installing the V-Drive, loosen all the nuts on the mounting brackets and check to see that the studs are in the center of the slots. Re-tighten the nuts. Place the V-Drive on the engine bed, lining it up "by eye" to the propeller shaft flange as closely as possible. Firmly bolt it down through the holes provided in the mounting plates. Loosen the locking nuts on the adjusting screws. Slightly loosen the nuts on the mounting brackets just enough to be able to move the V-Drive.

Many good installations are ruined by improper propeller shaft flange alignment. Accurate alignment will ensure a smooth operating drive train and eliminate many problems that arise due to misalignment. Final alignment should not be attempted until the boat has been allowed to "settle" in the water. Adjust the V-Drive until the pilot diameters of the gear shaft flange and the propeller shaft flange engage freely. Butt the flange faces together. Without rotating either flange, check with a feeler gage in at least four places as shown in the illustration. If the maximum feeler gage that can slip between the flange faces at any point is .003", the unit is properly aligned. If a thicker gage can be inserted at any point, the V-Drive must be readjusted until proper alignment is obtained. Turn the propeller shaft flange 1/4 of a turn without moving the gear shaft flange. Try inserting the .003" feeler gage as described above. The gap will not change if the propeller shaft is straight. If it increases, the shaft or flange is bent and must be removed and straightened. Rotate the propeller shaft flange in two more 1/4 turn increments and repeat the procedure. The pilot diameters must be rechecked to ensure that they still engage freely. Tighten the nuts on the mounting brackets and the locking nuts on the adjusting screws. Remove the set screws from the brackets (none on RV-10 or RV-20), spot drill and securely tighten. Recheck the flange alignment to make sure the V-Drive didn't move out of alignment. Secure the two flanges together with the heat treated bolts and special high collared lockwashers supplied.

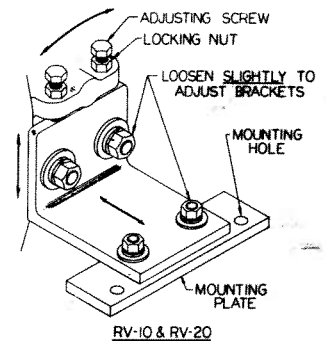

RV-10 & RV-20

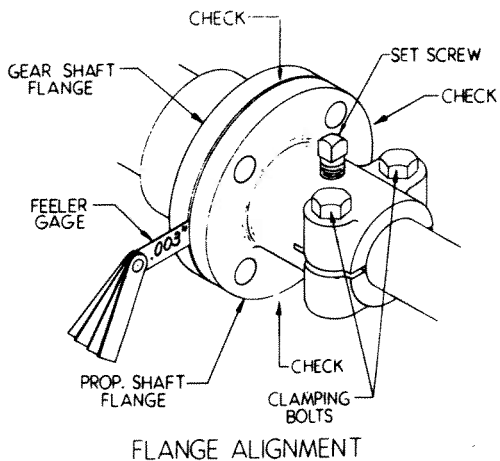

FLANGE ALIGNMENT

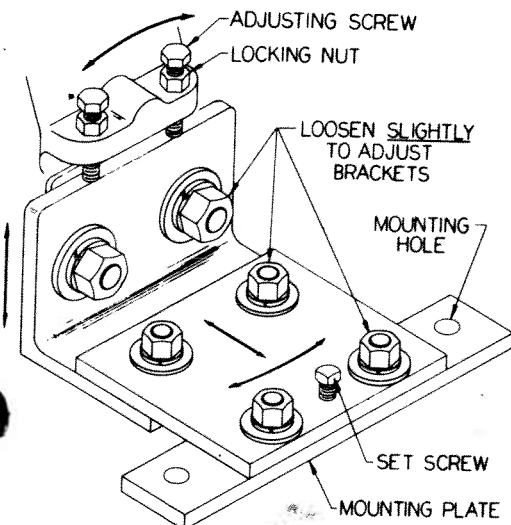

RV-30, RV-40 & RV-48

PARTS LIST

Advise serial number of V-Drive when ordering parts.

(A dash indicates a part is not used in that model.)

Part No.	DESCRIPTION	RV-10	RV-20	RV-30	RV-40	RV-48
1	Housing Main	1	1	1	1	1
2	Adapter Plate	1	—	—	1	1
3	Cover, no pump	1	1	1	1	—
3SP	Cover, pump	—	1	1	1	1
4	Cover, Seal	1	1	1	1	1
5	Cover, Blank	1	1	1	1	—
6	Cover, Watercooled	1	—	—	—	—
6B	Cover, Plain Bottom	—	1	1	1	1
6D	Cover, top	1	1	1	1	1
6E	Oil Cooling Coil	—	1	1	1	1
6F	Coil Terminal and O-Rings	—	2	2	2	2
8	Seal, Gear Shaft	1	1	1	1	1
9A	Pinion Shaft only	1	—	—	1	1
9AJ	Pinion Shaft and Yoke, 1 piece	—	1	1	—	—
9A-N	Locknut	—	1	1	1	1
9A-W	Lockwasher	—	1	1	1	1
9B	Pinion Gear	1	1	1	1	1
9C	Pinion Shaft Sleeve	—	1	1	1	1
9F	Spacer Ring	—	1	1	—	—
9W	Spacer, Flat	—	1	—	—	—
10	Driven Gear	1	1	1	1	1
11A	Gear Shaft	1	1	1	1	1
11A-N	Locknut	1	1	1	1	1
11A-W	Lockwasher	1	1	1	1	1
12	Breather Cap	1	1	1	1	1
12A	Breather Elbow	1	1	1	1	1
13	Gaskets, complete set	1	1	1	1	1
14	Bearing, Pinion Shaft, yoke end	1	1	1	1	1
14A	Bearing, Pinion Shaft, closed end	1	1	1	1	1
15	Bearing, Gear Shaft closed end (P = Pair)	1	1	1 (P)	1 (P)	1 (P)
15A	Bearing, Gear Shaft, flange end	1	1	1	1	1
16	Mounting Bracket, complete	2	2	2	2	2
17	Stud, Nut & Washers	4	4	4	4	4
18	Stud, Nut & L'Wash	16	20	20	24	24
19A	Screw & L'Wash	4	6	8	8	8

Part No.	DESCRIPTION	RV-10	RV-20	RV-30	RV-40	RV-48
19B	Stud, Nut & L'Wash	4	4	8	8	8
21	Oil Level Gage	1	1	1	1	1
22	Magnetic Plug	2	2	2	2	2
23	Angle Housing	1	1	1	1	1
23B	Stud, Nut & L'Wash	4	4	4	4	4
24	Angle Housing Cover	1	1	1	1	1
24A	Seal, Angle Housing	1	1	1	1	1
24C	O-Ring retainer	1	1	1	1	1
24E	O-Rings	2	2	2	2	2
24F	Wavy Washer	1	1	1	1	1
25	Prop Flange, complete	1	1	1	1	1
25B	H.T. Bolts & L'Wash	3	6	6	6	8
26	Bearing, self-aligning	1	1	1	1	1
27	Splined Connecting Shaft	1	1	1	1	1
28	Idler Gear	—	1	1	1	1
29	Idler Shaft	—	1	1	1	1
29A	Idler Bushing	—	1	1	1	1
29B	Idler Spacer & Shim	—	1	1	1	1
30	Idler Bearing	—	2	2	2	2
31A	Alignment Gage	1	1	1	1	1
33A	Spool Adapter	1	1	1	1	1
34	Universal Joint, Double complete	1	—	—	1	1
34A	Joint Repair Kit	1	1	1	1	1
34J	Univ. Joint, less Yoke	—	1	1	—	—
36	Adjustable Tubular Shaft	1	1	1	1	1
39	Flexible Joint	1	1	1	1	1
39A	Flexible Joint Flange	—	1	1	1	1
39D	H.T. Bolt & L'Wash	4	4	4	4	4
39E	H.T. Bolt, Nut & L'Wash	4	4	4	4	4
39F	H.T. Bolt, Nut & L'Wash	4	4	4	4	4
40	Disc Adapter	1	1	1	1	1
42A	Oil pump and Spring	—	1	1	1	1
42B	Pump End Cap	—	1	1	1	1
42T	Pump Drive Ring & Pin	—	1	1	1	1
43F	Screen	—	1	1	1	1
44	Hose & Hose Connections	—	1	1	1	1
45	Spray Nozzle	—	1	1	1	1
45C	Nozzle Holder	—	1	1	1	1
49	Pressure Drop Switch	—	1	1	1	1
49A	Warning Light & Plate	—	1	1	1	1

Drive System Assembly

• The V-Drive is connected to the reverse gear by a "floating" shaft assembly that eliminates strain between the engine and the V-Drive. It can move in and out and also angularly to take up slight (3° max.) engine misalignment. After the propeller shaft flange has been lined up, the #27 splined connecting shaft must be cut to the proper length. After cutting, tap it into the #39A flexible joint flange (do not tighten the set screw yet). Slip the spline shaft into the internal spline of the V-Drive to the proper depth ("AH" dimension — see table). If this length is shortened the spline can possibly run on the oil seal and/or O-ring and an oil leak may develop. A good method of maintaining this depth is to wrap a piece of tape around the shaft at the proper length before installation. Bolt the #40 disc adapter to the reverse gear flange. Install the #39 flexible joint between the joint flange and the disc adapter and bolt it in place. If the pilot diameters do not engage freely or if the faces do not fit flush, the engine must be preliminarily adjusted. Failure to do so may result in a bent spline shaft and/or internal damage to the V-Drive. The depth that the splined shaft enters the V-Drive ("AH" dimension) should be rechecked at this point. If it is not correct, the assembly must be removed. Tap the shaft either in or out of the #39A joint flange as required. Reinstall the entire assembly as described above and tighten the set screw in the joint flange.

The #36 adjustable tubular drive shaft is used for long installations. Insert the #27 splined connecting shaft (it need not be cut) into the split hub to the proper depth and tighten the two

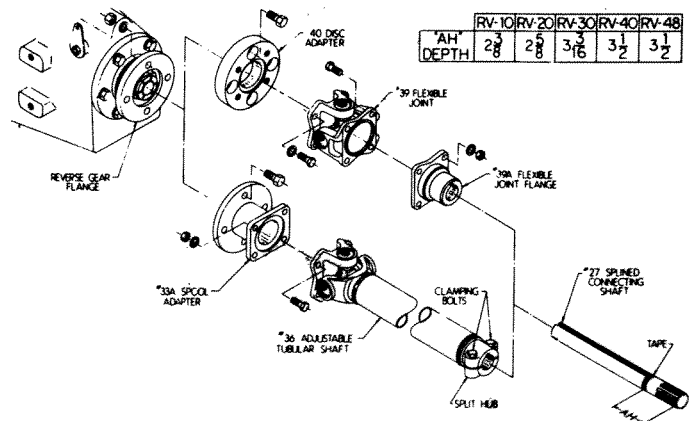

clamping bolts. Remove the #24 angle housing cover assembly, insert the splined shaft through it and into the internal spline of the V-Drive. Re-install the cover assembly to the V-Drive. Bolt the #33A spool adapter between the reverse gear flange and the flexible joint. Check the flange engagement and the "AH" dimension as described above.

On the RV-10 short installation only, the #39A joint flange and the #39 flexible joint assembly is one piece. Instead of the #40 disc adapter, a #33A spool adapter is used. Assembly is similar to the tubular drive shaft installation.

PARTS USED ONLY ON
UNITS EQUIPPED WITH
AN IDLER GEAR

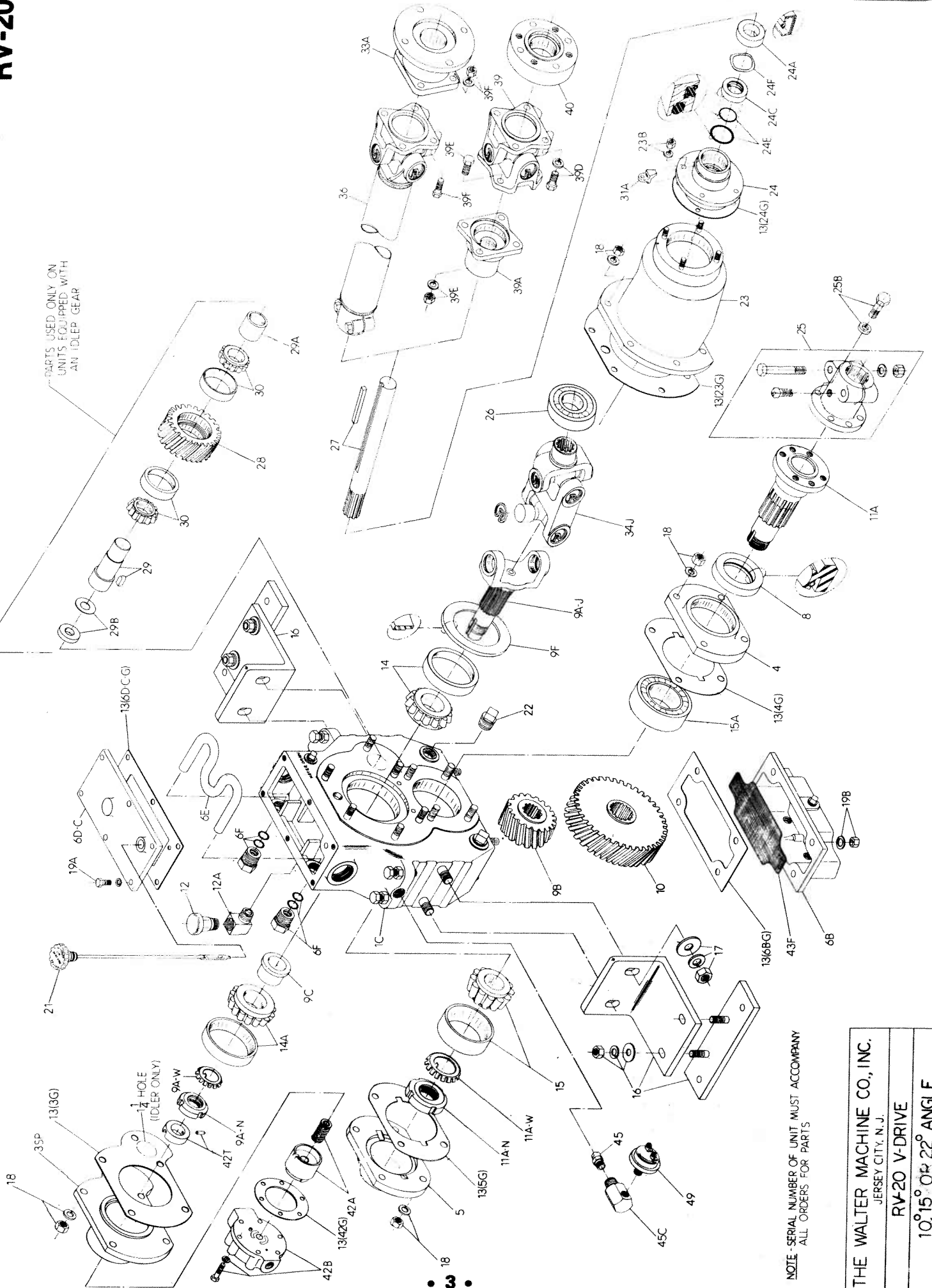

NOTE - SERIAL NUMBER OF UNIT MUST ACCOMPANY
ALL ORDERS FOR PARTS

THE WALTER MACHINE CO., INC.
JERSEY CITY, N. J.

RV-20 V-DRIVE

10°, 15° OR 22° ANGLE

INSTALLATION DRAWING

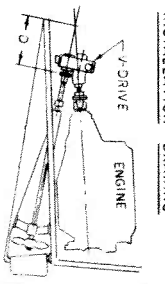

ANGLE	D	I	O	Q
10°	11	4 13/16	11 1/2	5 1/2
15°	13 1/2	5 1/2	11 1/2	5 1/2
22°	8 15/16	5 1/4	11 3/8	5 5/16

- NOTES:
- I - ALIGNMENT GAGE FOR POSITIONING & CHECKING ALIGNMENT BETWEEN ENGINE & V-DRIVE
 - II - 15° ANGLE STANDARD - CAN BE SUPPLIED WITH SPECIAL 10° OR 22° ANGLE
 - III - CUT SHAFT LENGTH TO SUIT
 - IV - INCREASE DIMENSIONS BY 1/2" FOR 2.05-1, 2.56-1 & 3.00-1 RATIOS

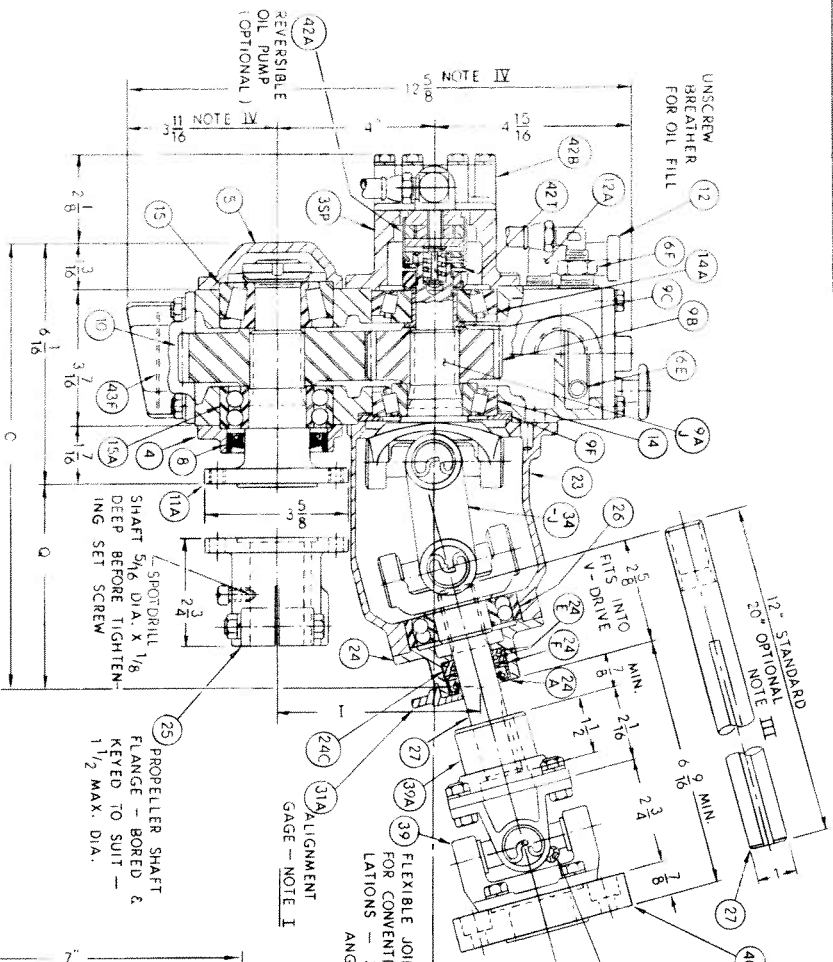

PIPING DIAGRAM (STANDARD)

PIPING DIAGRAM (WITH IDLER)

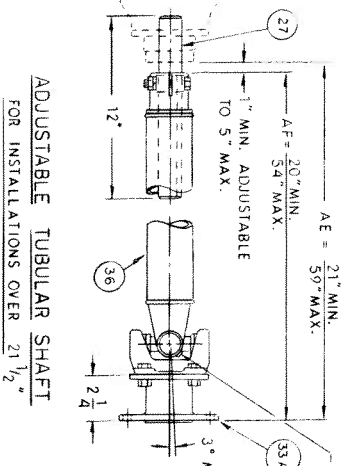
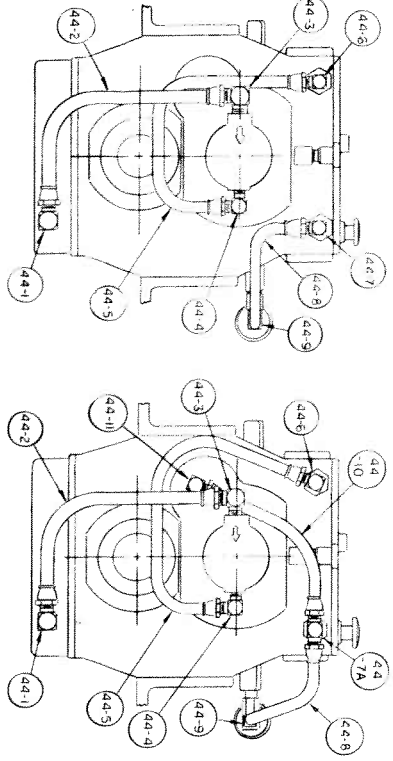

STANDARD RATIOS (REDUCTION)	HP/100 RPM (GASOLINE)	HP/100 RPM (DIESEL)
1.00-1	6.0	4.5
1.46-1	5.5	4.1
2.05-1	5.0	3.75
2.56-1	4.5	3.37
3.00-1	4.0	3.0

REV 3 26 80
REV 11-26-75

NOTE: MOUNTING BRACKETS HAVE 2-WAY ADJUSTMENT - 3/8" UP & DOWN AND 1/8" SIDWAYS

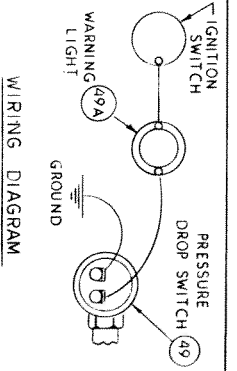

SECTION THRU IDLER

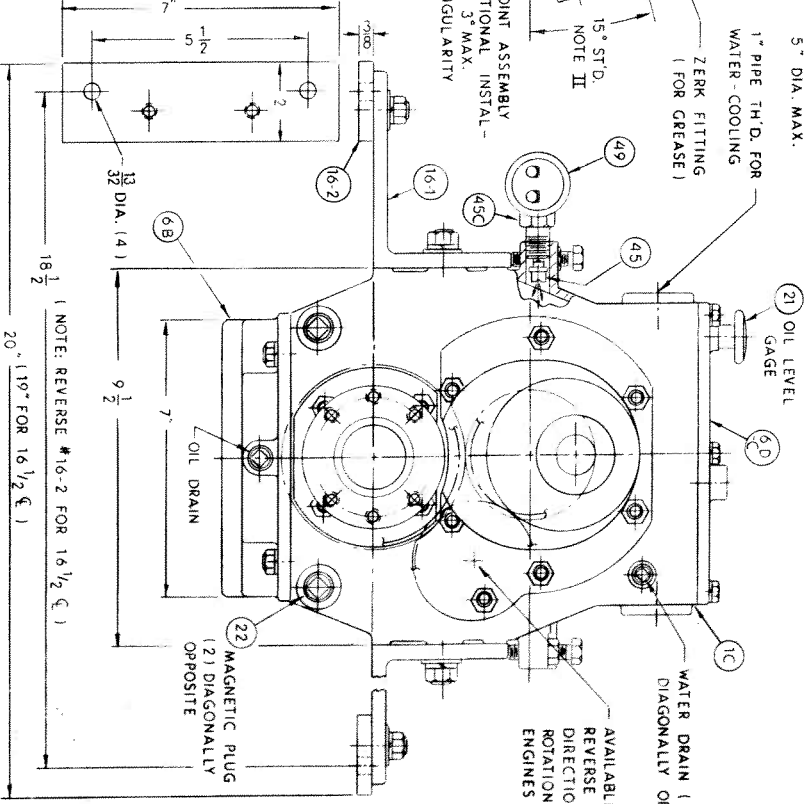
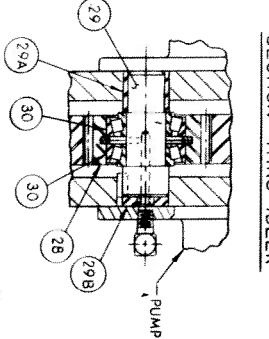

AVAILABLE WITH IDLER GEAR TO REVERSE PROPELLER SHAFT DIRECTION (TWIN SCREW ROTATION WITH SAME HAND ENGINES)

THE WALTER MACHINE CO., INC.
JERSEY CITY, N. J.

RV-20 V-DRIVE

ANGLE

GEO

Engine Alignment

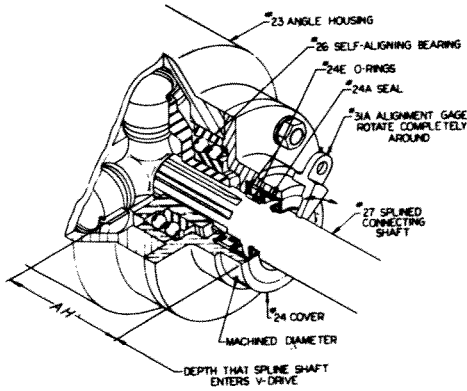

The engine must be adjusted so that the alignment of the flexible joint is within 3°. An accurate steel rule should be used for this purpose as shown in the illustration. On short installations using a flexible joint assembly, the faces of the flexible joint must be parallel within 1/8". Measure this in at least four places around the diameter without rotating the assembly. With long installations using the #36 tubular drive shaft (also on all RV-10's) the distance from the #33A spool adapter to the bores in the universal joint which is welded to the tubular shaft must be measured on both sides of the joint. Rotate the shaft exactly 1/4 of a turn and measure to the same joint. The four distances must be equal within 1/8". (Do not measure to the joint end that is on the spool adapter. This distance will not vary with misalignment since the joint is bolted on and cannot move.) Put the #31A alignment gage on the machined diameter of the #24 cover and slide it completely around. It will indicate how the engine must be moved to center the spline shaft in the oil seal. Re-measure the joints to see if they are still parallel within 1/8". It is important that both alignments be checked thoroughly. It is possible for the spline shaft to be perfectly centered and the flexible joint to be out more than 3°. Premature failure of the #26 self-aligning bearing and seals may occur due to misalignment. The zerk fitting (located on the cross of the universal joint) should be greased with a light alomite lubricant. The above procedure should be repeated after the boat has been placed in operation. It is possible for the engine to slightly shift and settle, especially if it has rubber mounts.

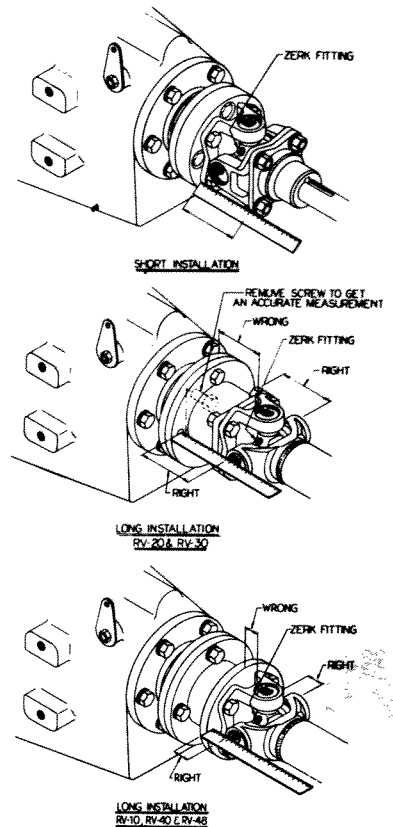

INSTALLATION DRAWING

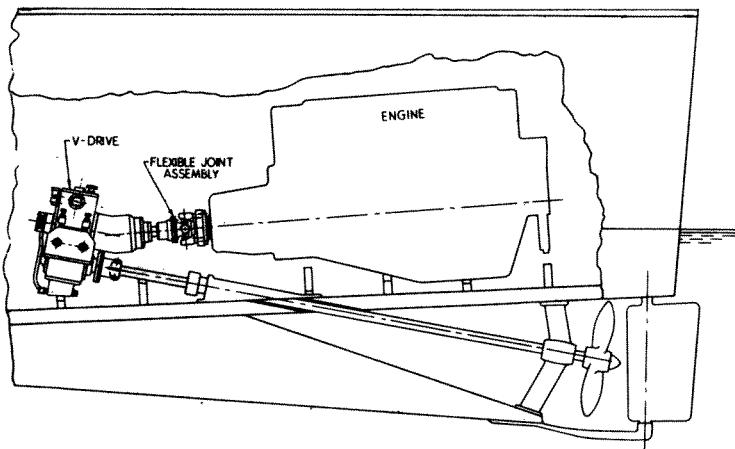

Water and Switch Connections

- Hook up the water lines to the two pipe connections on the V-Drive (intake and exhaust lines are interchangeable). Generally one line from the seacock to the V-Drive and another from the V-Drive to the intake of the engine water circulating pump are utilized. In some cases, scuppers through the hull are connected to and from the V-Drive to provide independent water-cooling and are actuated by the movement of the boat through the water. With closed cooling systems, the V-Drive should be incorporated into the system between the cooler and the suction side of the water pump. Proper operating temperatures are from 140° to 180°F, although safe operating temperatures may be as high as 210°F. On the models equipped with an oil circulating pump, the #49 oil pressure drop switch and the 12 volt #49A warning light should be hooked up per the wiring diagram (see page 4). The switch may be grounded to any part of the V-Drive or engine (either terminal may be used for the ground).

Oil Fill

- Pull out the #21 oil level gage. Unscrew the #12 breather cap and fill the V-Drive with SAE #30 motor oil through the #12A breather elbow. On the RV-10 only, the oil may be added by removing the plug in the #6D top cover. See table below for approximate oil capacities. The amount varies with the angle of installation. The oil level should be checked with the oil level gage fully inserted in the unit. The proper level is between the "H" and "L" marks on the gage. Add a 2 ounce tube of Molykote (molybdenum disulfide), which is supplied with each V-Drive for extra lubrication and break-in. It provides protection against scoring or galling of gears, bearings and other moving parts. Additional Molykote after break-in is not required. Reinstall the breather cap. The oil level should be rechecked after the unit has been run and allowed to sit for about a minute. Add oil if necessary.

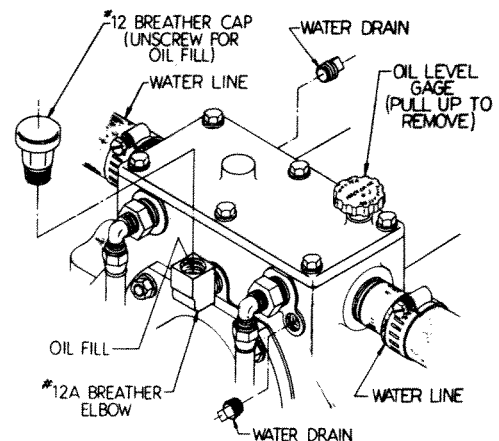

	RV-10	RV-20	RV-30	RV-40	RV-48
Oil Capacity (Approx.)	1 pint	2 pints	3 pints	4 pints	4 pints

Operation

• A pressure drop warning light is mounted on the instrument panel on V-Drives equipped with an oil circulating pump. The warning light will stay lit until the boat gets under way and the engine speed increases to sufficient RPM for the pump to maintain pressure. This normally occurs at approximately 1200 RPM, but the actual speed may vary by as much as 400 RPM. Extended cruising at low RPM, such as when trolling, is not harmful to the V-Drive, even though the warning light may stay lit. Normal operation is between 6 to 12 PSI. The light will go on when the oil pressure drops below 2 PSI. Loss of oil and/or insufficient oil level are the major causes of pressure drop. The oil level should immediately be restored, and while running the boat, the unit should be checked for leaks. If the oil level is normal and the light stays lit when the boat reaches normal cruising speed, the wiring should be checked for loose and/or corroded connections. If the wiring is correct and the light remains lit, the #49 pressure drop switch, which is mounted on the side of the V-Drive (see illustration), should be checked for proper operation. The switch can easily be removed and an accurate oil pressure gage installed in its place. If the pressure is normal, the switch should be replaced. If the pressure is below normal, the oil lines should be checked for blockage. The pump should be inspected and replaced if necessary. The pump is standard on the RV-48 and an optional feature on other models (not available on the RV-10).

The oil level should be checked several times during the season, especially on V-Drives without pumps (see "Oil Fill").

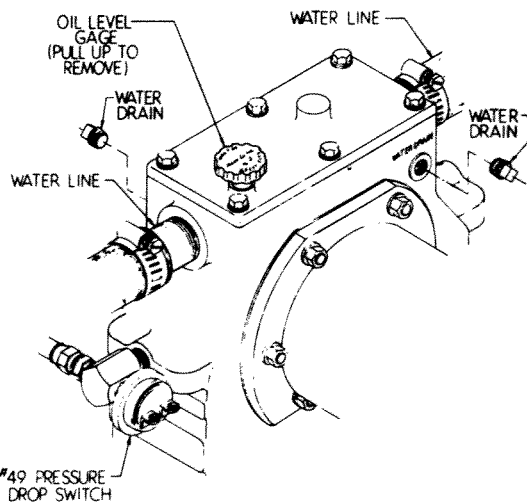

A clatter or rattle in the V-Drive at low RPM is due to the over-riding of the propeller during the compression stroke of the engine. Although annoying, it is not harmful. It may be reduced by adjusting the idle speed and/or tuning up the engine for smoother operation.

Maintenance

Oil Change & Joint Lube

• After the first 100 hours of operation and every season and/or 500 hours thereafter, the oil should be changed. Run the boat to warm up the V-Drive to operating temperature. With the engine turned off, remove any one of the plugs in the #6B bottom cover to drain the oil. The removal of only one plug is necessary. Reinstall the plug after draining. Unscrew the two #22 magnetic plugs that are located on diagonally opposite corners of the #1C main housing. The plugs can be checked to see if they are magnetic only after removal. Touch the inside face with a metallic object, such as a screwdriver. Clean them and reinstall. Usually there are four plugs in the bottom part of the main housing. Only two of these are magnetic. The other two need not be removed (see illustration). Refill with SAE 30 motor oil to the proper level (see "Oil Fill"). The Zerk fitting on the external universal joint should be greased with a light alemite lubricant (see "Engine Alignment").

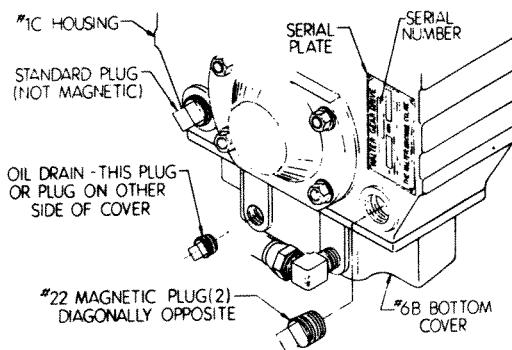

Water Drain

• For protection from freezing during winter lay-up, remove the small pipe plugs (located diagonally opposite) on the front and back of the housing marked "Water Drain" (see illustration). On the RV-10 only, one of the water lines going into the #6 water-cooled bottom cover must be disconnected to drain the water.

Flange & Engine Realignment

• When the boat is launched after being in drydock, the line-up of the V-Drive to the propeller shaft flange and the engine to the V-Drive should be rechecked and corrected if necessary. Some engines with rubber mounts may sag and must be raised with adjustments or shims for proper alignment (see "Flange Alignment" and "Engine Alignment").

Dealer Preparation

• The propeller shaft and engine alignment must be checked and corrected, if necessary, before the boat is delivered. Final alignment should not be attempted until the boat is allowed to "settle" in the water. The oil level must be checked and oil added if required. While the boat is being run, the water connections should be checked for leaks. The oil pressure drop switch and warning light (if the V-Drive is equipped with an oil circulating pump) should be checked for proper operation. Do not transport the boat with the propeller shaft coupling connected. Damage to the shaft, shaft log and V-Drive can result.

DANGER: Do not touch V-Drive or related components until all shafts and exposed parts are stopped and the ignition is off. All repair and maintenance must be done by a person who is fully qualified.

LIMITED ONE YEAR WARRANTY — All assembled V-Drives and parts are warranted against defective material or workmanship for a period of twelve months or 400 hours of operation, whichever occurs first, from date of delivery. The Walter Machine Co. Inc. obligation under this warranty is limited to replacement or repair of any defective material when returned prepaid to our factory in Jersey City, and shall be subject to our inspection and verification of claim. Each V-Drive has a serial number on a nameplate on the side of the main housing, which must be submitted when making warranty claim. This warranty will not apply to any failure which results from accident, neglect, fire, sinking, abuse, abnormal service, lack of maintenance or improper installation or service. This warranty will not apply to haul-out, launch, towing or storage charges, mechanic travel time, inconvenience, loss of time or income, removal and replacement and/or modification of any boat parts to facilitate repairs. The Walter Machine Co. Inc. will not accept responsibility for contingent liability through failure of any complete unit or part.

Manufactured by: **THE WALTER MACHINE CO., INC.** • 84-98 CAMBRIDGE AVENUE • JERSEY CITY, N.J. 07307
TELEPHONE: (201) 656-5654